

HOME

ABOUT US

OUR SERVICES

- Ocean Freight
- Air Freight
- Land Transport Solutions
- Customs Clearance
- LCL Consolidation
- Warehousing & Distribution
- Project Cargo & Heavy Lift
- ISO Tanks, Flexi Tanks & DG Cargo
- Cargo Insurance

KNOWLEDGE BANK

- Container Specifications
- INCO Terms
- Shipping Terms Dictionary
- Conversion Tables
- World Seaports
- World Airports

ENQUIRY FORM

CONTACT US

# ABOUT US

Centaurus Sky Shipping LLC ("CSKY") provides a multitude of shipping activities with Freight Forwarding operations as its core business offering multi model transportation services in containerized, non-containerized, break-bulk and project cargo within the region encompassing INDIA – MIDDLE EAST – SE/FE ASIA & Africa.

We offer seamless services such as Sea Freight, Air Freight and Road Freight. CSKY is capable to handle all types of transportation jobs from shipper door to consignee door anywhere in the world and can offer the highest levels of service standards such as reliability, honesty, accuracy, close communication and commitment along with ethical principles and practices.

With our strong international agency network around the globe, we can provide first class service with competitive rates to all the destinations worldwide.

At CSKY, we believe in establishing strong partnership and close working relationship with all our customers and counter parts around the globe to offer comprehensive total supply chain solutions. We continuously provide cost-effective solutions to all our varied customers.

Our independent overseas representatives and partners are appointed after careful screening to ensure our policy standards is not compromised. A team of enthusiastic and talented professional's staff at CSKY helped us to become one of the trusted and recognized names in the freight forwarding field. No matter small or large volumes we handle all cargo with utmost care and offer the finest personalized attention and services.

We cater to all below shipping requirements,

- Ocean Freight
- Air Freight
- Land Transport Solutions
- Customs Clearance
- LCL Consolidation
- Warehousing & Distribution
- Project Cargo & Heavy Lift
- ISO Tanks, Flexi Tanks & DG Cargo
- Cargo Insurance

# OUR SERVICES

## OCEAN FREIGHT

At CSKY we work with selected quality carriers offering multiple shipping options, competitive transit times and maximized container availability. The combination of our global reach, local expertise and personal service helps your company reach your goals through efficient logistics. CSKY offers a single-source solution to the complexities of ocean freight, giving you the freedom to use your energy where you need it most "Focusing on your Trade". CSKY with its well renowned business partners are uniquely positioned to synchronize the supply chain needs end to end at all levels. Our flexible range of ocean services meets the needs of any customer.

We offer:

- FCL, LCL and Break Bulk booking services
- On-dock and Off-dock cargo stuffing facilities
- Economic and workable rates
- Advanced trace & track facilities
- Confirmed space allocation with all major shipping lines
- Efficient staff at customs and port zone
- Strong links with local customers
- Highly skilled professionals in shipping industry at your service.
- Licensed customs broker
- Export and import customs clearance
- Customized solutions for challenging trades and shipments

## AIR FREIGHT

If you are weighed by time constraints, then there is no option other than sending your items by air freight. When you are in hurry to send air freight entrust your job to us. With years of experience and well-connected networks we will be able to meet your deadlines leaving you with the freedom to dedicate your valuable time for other important matters. We offer tailor made services to suit the needs of each customer with the best prized solutions. Founding principle of CSKY is to provide world-class services with a personal attention. We offer fast, safe and reliable service to almost all destinations globally.

Our Air Freight forwarding solution offers:

- Freight forwarding to arrival airports or door to door delivery
- Direct airline and express services for more urgent consignments
- Confirmed space allocation facilities with all reputed Air Carriers
- Cargo Pick-up / Delivery Services
- Personalized customer service units geared-up to face any eventualities
- Highly skilled professionals in shipping industry at your service
- Storage and warehousing

## LAND TRANSPORT SOLUTIONS

CSKY operates with a fleet of many trailers specifically designed to carry heavy weight ISO containers, standard containers, bulk and liquid product tankers. We specialize in movement of loaded container from the docks to the importers door with complete documentation and high level of perfection and with emphasis on long term contracts with Shippers and Importers. We qualify in servicing those customers who require time definite service. Our time perfection and professional approach enables us to develop a good rapport with the customer, who are ease with perfect information flow through are qualified customer service and operation department. Our transport experience we have been one of the most dependable and efficient transport service provider in Dubai and we take pride to say that we can handle all complex situations in the Transport sector from any gateway ports across Dubai.

Multimodal Transport services at CSKY is an effective chain that interconnects different links or modes of transport – air, land & sea into one complete process that ensures an efficient and cost-effective door-to-door movement of goods under a single roof. Our comprehensive and high-capacity network allows us to provide you with a fast and flexible service. Our sea links allows us to fully serve customers with tailor made solutions to fit their specific door-to-door transportation needs, whether it is smaller consignments, part-loads or full-loads.

The most far-reaching impact of containerization on our part is our involvement in multimodal transport; we have a proven track of carriage of goods by more than one mode of transport under a single contract. As a multimodal transport operator, we assume responsibility for the execution of the multimodal transport contract, and of the carriers participating in the multimodal transport operations. We have excellent business links with individual transport operators and provide the best of services. Our Multimodal transport, which is planned and coordinated as a single operation, minimizes the loss of time and the risk of loss, pilferage and damage to cargo at trans-shipment points. We maintain excellent communication links and coordinate interchange and onward carriage smoothly at trans-shipment points.

## CUSTOMS CLEARANCE

We are a full-fledged Customs Clearing Agent in UAE offering wide variety of services in order to help the clients for Import and Export Customs Clearances. With updated Customs regulations and procedures, we handle clearance of consignments by Sea, Air and Land more efficiently.

We can clear all types of shipments, major or minor, for/from across the globe to the utmost satisfaction of clients due to our long years of expertise and wide exposure in this field.

Our personnel are well cognizant with the challenging needs and changing demands of today's businesses. They deal with your day-to-day problems and formalities involved in the respect of clearance of import and export cargo.

With the required documents, our team of dedicated professionals get the customs clearance and ensure end-to-end solution for export or import of the good in the most cost-effective manner

We ensure:

- Commitment to achieve customers' requirements
- Highly efficient working procedures
- Experience in handling different commodities
- Customer centric policy and actions approach
- Complete documentation
- IT enabled system

## LCL CONSOLIDATION

Through our worldwide network, we are tied up with convenient regional container freight stations (CFS) located globally, providing service availability for less than container loads (LCL) and consolidation services, either by sailing, weekly, every other week or in accordance with your requirements. Cost-effective transportation solutions for shippers of not only large but also small volume shipments. Door to Door delivery, technological infrastructure that enables us to accurately communicate the cargo loading details, viz. head load, tail load, center load, to our international counterparts so that they can unload the Container / Unit Load Device in a systematic order depending on the customer's specifications.

We facilitate communications and monitoring of your shipments with your vendors, shippers, trading networks and buying offices and perform consolidation services according to your specific instructions. We provide booking status, loading reports and arrival notification for all shipments to ensure that LCL cargo location is known every step of the way.

Additional services for LCL Consolidation:

- Right cargo combination for LCL shipments ensuring full safety to our customer's cargo
- Door to door pick-up and delivery
- Export processing and permit applications and certifications
- Warehousing and Distribution
- Inventory management
- Customs clearance and formalities

## WAREHOUSING & DISTRIBUTION

Warehousing and distribution are a key component of the integrated logistics and shipping system for companies seeking a cost-effective method of distributing their range of products. Our group and associate companies operate their own container freight stations for cargo consolidation, packing and shipping. At these locations there is available advanced warehousing and distribution hubs for both corporate and general clients, delivery services ranging from receiving, inventory control and the ability to pick and pack a variety of commodities for direct delivery to customer's doorstep.

Key features include:

- 3PL & 4PL
- Cross stuffing
- Supply chain management
- Lashing & Skidding
- Pick & Pack
- Personal Effects & Relocations
- Exhibition Cargo
- Perishable cargo



## PROJECT CARGO & HEAVY LIFT

CSKY is experienced in intricate logistical challenges. Our well experienced professionals can help you in evaluating your project requirements. We believe in providing world-class services with a personal attention. We work closely with our customers to ensure safe handling of valuable shipment thus saving time and money. Our close relationships with our clients over the years, the trust we have developed help us to have open communication to provide a thriving project experience. We are able to offer customized services with immense expertise and industry experience. Handling project cargo requires relevant experience, equipment & manpower. We have a successful track record of handling super heavy lifts.

We are well equipped with efficient and effective infrastructure facilities to handle all types of project cargoes. We have experienced and specialized personnel for project cargo logistics and have access to the full range of material handling equipment such as cranes, lighters, heavy lift trucks for sea and overland operations. Depending on your personal needs we will develop the total solution to ensure the best possible operational arrangement to move your cargo.

Our professionals and well-connected networks ensure the correct documentation and swift movement of cargo. Call us for further clarifications.

- Feasibility Studies for special transports
- Mobilization of equipment
- Technical assistance
- Customs clearance
- Real time status reports

## ISO TANKS, FLEXI TANKS & DG CARGO

ISO tanks are the revolutionary concept in the transportation of liquid, gaseous and powder chemicals. They provide a sturdy safe and user-friendly mode of loading, carriage, transportation, shipping and discharge of various hazardous, non-hazardous and food grade chemicals adhering to the international norms regulations of safety.

We serve our valuable customers for worldwide locations for Export and Import through our partners of ISO Tank agents, for spot shipment, nomination / dedicated shipments.

We offer perfect solutions to our customers Flexi Tanks requirements. Flexi-Tanks varying in sizes from 15KL to 24KL fit to carry any non-hazardous liquid chemicals catering even to the food industry. Our flexi-tanks are FDA approved and are made from virgin Polyethylene under strict quality control measures to minimize risks of leakage.

CSKY's team has over 25 years in shipping industry experience. This allows to provide the safety and care required for specialized hazardous cargo movements. Our staff is trained as per IMO regulations to handle hazardous cargo meeting even the most stringent compliance and safety requirements.

CSKY has a strong commitment to principles of safety, health and environmental protection in the storage, transportation and delivery of dangerous goods. Strict controls are in place to ensure that these cargoes are handled safely. We are experts in shipping / air freighting hazardous cargo that are fully compliant with IMDG, ADR and IATA Regulations. We specialize in handling the issuance of dangerous goods declaration, classification, packing, re-packing, labeling and transport. We have built a reputation of being experts in the world of hazardous cargo and are often contacted by other forwarders and liners for advice.

## CARGO INSURANCE

While CSKY primarily arranges for the transportation of your goods, our insurance solutions provide the owner of the cargo financial protection against all risks of physical loss or damage from any external cause. The insurance provides risk coverage for ocean, air and road freights. Our Cargo Insurance Services are value added services. We have tie ups with major Insurance Companies in UAE and India giving our customers wide range of coverage to choose from. Insurance services from CSKY also provide coverage for stored goods at the company's warehouse. In the event of a loss or damage, the insurance surveyors are available for responsive and complete inspections. Cargo insurance provides extra peace of mind for the valued customers.

Cargo Insurance Services is authorized and regulated by the Financial Services Authority (FSA) to provide freight insurance. We are able to arrange insurance cover, at extremely competitive premiums, for all your import and export cargo. Our highly trained employees are on hand to provide guidance as to the options available and provide immediate open general marine insurance quotes.

# KNOWLEDGE BANK

## CONTAINER SPECIFICATIONS

### 1. STANDARD CONTAINERS / DRY CARGO CONTAINERS

Standard Containers are also known as general purpose containers. They are closed containers, i.e., they are closed on all sides. These can fit most of your common needs. Standard containers are designed and constructed for transportation of general cargo on sea, rail and land. They are also able to withstand extreme temperatures ranging from -40° C (-40° F) to 70° C (158° F) without affecting their strength and water tightness. Standard Containers are used for all types of general cargo (dry cargo). While High Cube Containers are also used for all types of general (dry) cargo, however they are particularly suitable for transporting light, voluminous cargoes and over height cargoes up to a maximum of 2.70m tall.

Dimensions	Length	Width	Height
<b>External</b>	6096 mm	2362 mm	2590 mm
<b>Internal</b>	5944 mm	2337 mm	2388 mm
<b>Door Openings</b>		2337 mm	2286 mm
Weights			Capacity
Max. Gross	Tare	Max. Payload	
24000 kg	2080 kg	21920 kg	33.9 m <sup>3</sup>



20FT Dry Container

Dimensions	Length	Width	Height
<b>External</b>	12192 mm	2438 mm	2591 mm
<b>Internal</b>	12014 mm	2286 mm	2388 mm
<b>Door Openings</b>		2337 mm	2286 mm
Weights			Capacity
Max. Gross	Tare	Max. Payload	
30480 kg	3900 kg	26580 kg	67.7 m <sup>3</sup>



40FT Dry Container

Dimensions	Length	Width	Height
<b>External</b>	12192 mm	2438 mm	2896 mm
<b>Internal</b>	11963 mm	2362 mm	2692 mm
<b>Door Openings</b>		2286 mm	2591 mm
Weights			Capacity
Max. Gross	Tare	Max. Payload	
30480 kg	4150 kg	26330 kg	76.4 m <sup>3</sup>



40FT High Cube Container

## 2. REFRIGERATED (REFEER) CONTAINERS

These types of refrigerated containers (“reefers”) have an integral refrigeration unit for controlling the temperature inside the container. When being transported by ship, integral units have to be connected to the on-board power supply system. For transport by road and rail, most integral refrigeration units are operated by a generator set (genset). These reefers are used for goods which need to be transported at a constant temperature above to below freezing point. These goods are divided into chilled goods and frozen goods, depending on the specified transport temperature. The goods transported mainly include, fruits, vegetables, meat and dairy products, such as cheese and butter. High cube reefers are used for voluminous and light goods (e.g., fruits and flowers).

Dimensions	Length	Width	Height
<b>External</b>	6096 mm	2370 mm	2591 mm
<b>Internal</b>	5455 mm	2260 mm	2275 mm
<b>Door Openings</b>		2237 mm	2260 mm
Weights			Capacity
Max. Gross	Tare	Max. Payload	
27000 kg	3050 kg	23950 kg	28.0 m <sup>3</sup>



20FT Reefer Container

Dimensions	Length	Width	Height
<b>External</b>	12192 mm	2438 mm	2591 mm
<b>Internal</b>	11555 mm	2286 mm	2280 mm
<b>Door Openings</b>		2285 mm	2245 mm
Weights			Capacity
Max. Gross	Tare	Max. Payload	
30480 kg	4370 kg	26110 kg	60.2 m <sup>3</sup>



40FT Reefer Container

Dimensions	Length	Width	Height
<b>External</b>	12192 mm	2438 mm	2895 mm
<b>Internal</b>	11560 mm	2286 mm	2500 mm
<b>Door Openings</b>		2286 mm	2478 mm
Weights			Capacity
Max. Gross	Tare	Max. Payload	
30480 kg	4200 kg	26280 kg	60.2 m <sup>3</sup>



40FT High Cube Reefer

### 3. FLAT RACK CONTAINERS

The Flat racks consist of a floor structure with a high loading capacity composed of a steel frame and a softwood floor and two end walls, which may either be fixed or collapsible. The end walls are stable enough to allow cargo securing means to be attached and several flat racks to be stacked on top of one another. Flat racks are available in 20FT and 40FT sizes. Flat Racks are mainly used to transport heavy-lifts and over height or over width cargoes.



20FT Flat Rack Container

40FT Flat Rack Container

40FT High Cube Flat Rack Container

Size	Weights			Internal Dimensions		
	Max. Gross	Tare	Max. Payload	Length	Width	Height
<b>20FT Flat rack</b>	34000 kg	2740 kg	31260 kg	6038 mm	2438 mm	2213 mm
<b>40FT Flat Rack</b>	30480 kg	4200 kg	26280 kg	12086 mm	2224 mm	1981 mm
<b>40FT High Cube Flat Rack</b>	45000 kg	5700 kg	39300 kg	12060 mm	2365 mm	2245 mm

#### 4. OPEN TOP CONTAINERS

The open top containers have the following typical distinguishing structural features. The roof consists of removable bows and a removable tarpaulin. The door header may be swivelled out. These two structural features greatly simplify the process of packing and unpacking the container. In particular, it is very easy to pack and unpack the container from above or through the doors by crane or crab when the roof is open, and the door header is swivelled out. It should be noted, however, that the purpose of the roof bows of an open top container is not solely to support the tarpaulin but also to contribute to container stability. Usual open top container dimensions are 20FT and 40FT. Open top containers are used for all types of general (dry) cargo especially the tall cargo.



Size	Weights			Capacity	Dimensions	Length	Width	Height
	Max Gross	Tare	Max Payload					
20FT	30480 kg	2350 kg	28130 kg	32.5 m <sup>3</sup>	External	6096mm	2362 mm	2590 mm
					Internal	5888mm	2345 mm	2365 mm
					Door Openings		2335 mm	2280 mm
					Roof Openings	5415 mm	2205 mm	
40FT	30480 kg	3850 kg	26630 kg	66.4 m <sup>3</sup>	External	12192mm	2438 mm	2591 mm
					Internal	12029mm	2342 mm	2376 mm
					Door Openings		2336 mm	2230 mm
					Roof Openings	11544mm	2230 mm	

## 5. TANK CONTAINERS

The tank containers are used for liquid cargoes such as

- Fruit juices, spirits, sweet oils
- Chemicals, hazardous materials such as fuels, toxic substances, corrosion protection agents.

If the cargo requires temperature-controlled transport, tank containers can be equipped with insulation or heating.

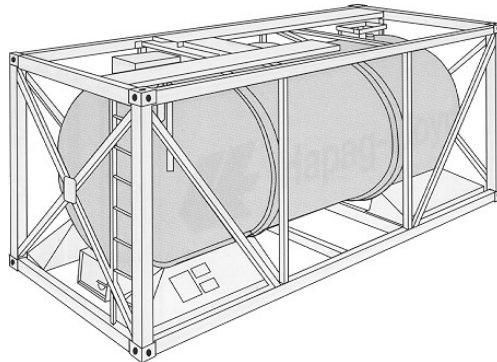

20FT Tank Container

External Dimensions To ISO		
Length	Width	Height
6058 mm	2438 mm	2438 mm
Weights		
Max. Gross	Tare	Max. Payload
30480 kg	4190 kg	26290 kg



# INCO TERMS

GROUPS											
	Any mode of transport			Sea and inland waterway transport			Any mode of transport				
FREIGHT TERMS	Freight Collect Terms				Freight Prepaid Terms						
INCOTERMS*	EXW	FCA	FAS	FOB	CFR	CIF	CPT	CIP	DAP	DPU	DDP
	Ex Works (Place)	Free Carrier (Place)	Free Alongside Ship (Port)	Free on Board (Port)	Cost & Freight (Port)	Cost, Insurance & Freight (Port)	Carriage Paid to (Place)	Carriage, Insurance Paid to (Place)	Delivered at Place (Place)	Delivered at Place Unloaded (Place)	Delivered Duty Paid (Place)
RISK TRANSFER	At Buyer's Disposal	On Buyer's Transport	Alongside Ship	On Board Ship	On Board Ship	On Board Ship	At Carrier	At Carrier	At Named Place	At Named Place Unloaded	At Named Place
OBLIGATION & CHARGES											
Export Packing	Seller	Seller	Seller	Seller	Seller	Seller	Seller	Seller	Seller	Seller	Seller
Loading Charges	Buyer	Seller	Seller	Seller	Seller	Seller	Seller	Seller	Seller	Seller	Seller
Delivery to Port/Place	Buyer	Seller	Seller	Seller	Seller	Seller	Seller	Seller	Seller	Seller	Seller
Export Duty, Taxes & Customs Clearance	Buyer	Seller	Seller	Seller	Seller	Seller	Seller	Seller	Seller	Seller	Seller
Origin Terminal Charges	Buyer	Buyer	Seller	Seller	Seller	Seller	Seller	Seller	Seller	Seller	Seller
Loading on Carriage	Buyer	Buyer	Buyer	Seller	Seller	Seller	Seller	Seller	Seller	Seller	Seller
Carriage Charges	Buyer	Buyer	Buyer	Buyer	Seller	Seller	Seller	Seller	Seller	Seller	Seller
Insurance Charges	Negotiable	Negotiable	Negotiable	Negotiable	Negotiable	Seller	Negotiable	Seller	Negotiable	Negotiable	Negotiable
Destination Terminal Charges	Buyer	Buyer	Buyer	Buyer	Buyer	Buyer	Seller	Seller	Seller	Seller	Seller
Delivery to Destination	Buyer	Buyer	Buyer	Buyer	Buyer	Buyer	Buyer	Buyer	Seller	Seller	Seller
Unloading at Destination	Buyer	Buyer	Buyer	Buyer	Buyer	Buyer	Buyer	Buyer	Buyer	Seller	Buyer
Import Duty, Taxes and Customs Clearance	Buyer	Buyer	Buyer	Buyer	Buyer	Buyer	Buyer	Buyer	Buyer	Buyer	Seller

\* For full and complete description of each incoterm, refer to full version Incoterms 2020 by the Institute of Chamber of Commerce at the ICC Website.

## SHIPPING TERMS DICTIONERY

Click here to download detailed glossary of all standard terms used in shipping industry.



Shipping Terms  
Dictionary.pdf

## CONVERSION TABLES

Direct to following weblink.

<http://erp.fresaxpress.com:19787/apex/f?p=201:969:13988299202886::NO:969::>

## WORLD SEAPORTS

Direct to following weblink.

<http://erp.fresaxpress.com:19787/apex/f?p=107:733:0::NO::>

## WORLD AIRPORTS

<http://erp.fresaxpress.com:19787/apex/f?p=107:734:0::NO::>

# ENQUIRY FORM